

Brake Pad



Inspection/Replacement

WARNING Do not use an air hose to blow the brake assembly clean. Use an OSHA-approved vacuum cleaner, to avoid breathing brake dust.

1. Remove the front wheels and support the front of car on safety stands.
2. Remove caliper bolt, brake hose bolts and pivot caliper up out of the way.

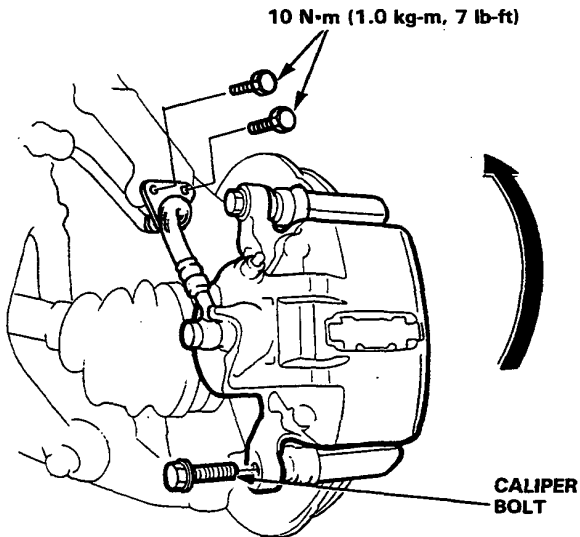

3. Remove the pad shim, pad retainers and pads.
4. Using a vernier caliper, measure the thickness of each brake pad lining.

Brake Pad Thickness:

CARB.

Standard: 9.0 mm (0.34 in)

Service Limit: 3.0 mm (0.12 in)

PGM-FI

Standard: 11.5 mm (0.45 in)

Service Limit: 1.6 mm (0.06 in)

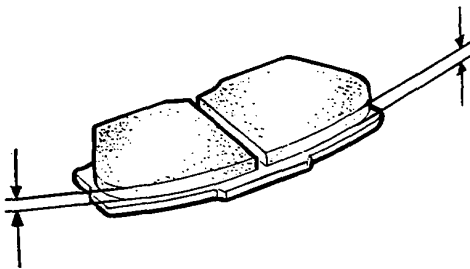

NOTE: Measurement does not include pad backing thickness.

5. If lining thickness is less than service limit, replace both pads as a set.

NOTE: Engagement of the brake may require a greater pedal stroke immediately after the brake pads have been replaced as a set. Several applications of the brake pedal will restore the normal pedal stroke.

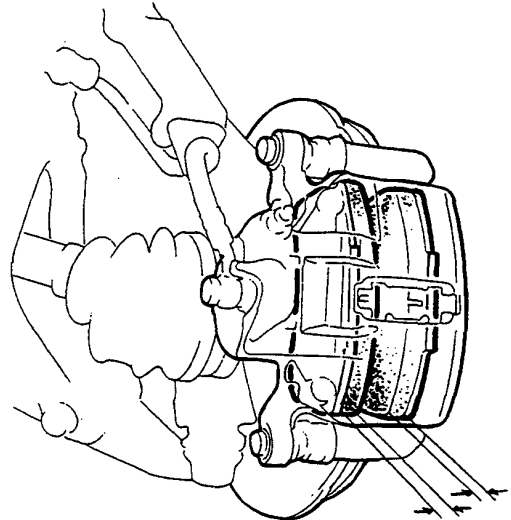

6. Clean the caliper thoroughly; remove any rust, and check for grooves or cracks.
7. Install the pad retainers.

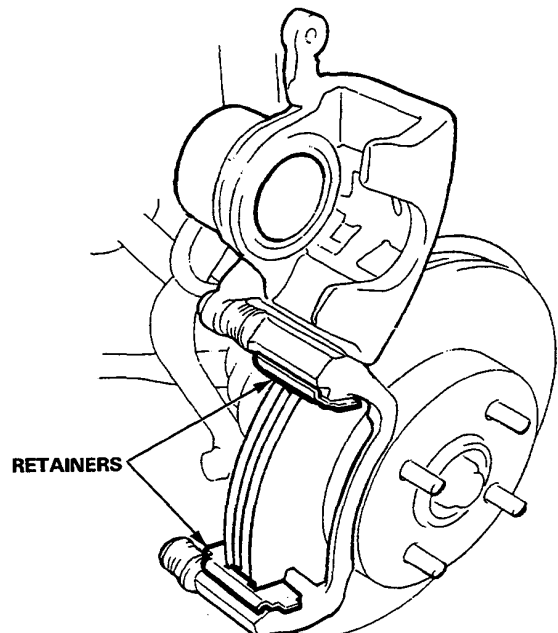

(cont'd)

Brake Pad

Inspection/Replacement (cont'd)

8. Apply MOLYKOTE M77 or equivalent to both surfaces of the shim and back of the pads.

9. Install the brake pads.

NOTE: Apply MOLYKOTE M77 or equivalent between the shims and pads.

10. Install the brake pad shims correctly.

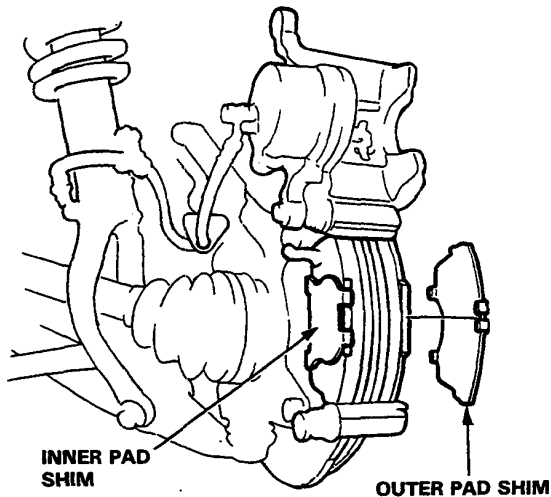

11. Push in the piston so that the caliper will fit over the pads.

12. Pivot the caliper down into position, then install the caliper bolt and tighten it.

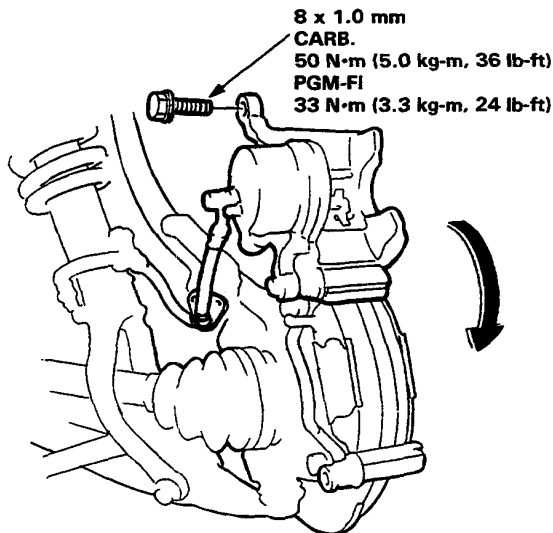

13. Connect the brake hose to the knuckle.

14. Depress the brake pedal several times to make sure the brakes work, then road-test.

Brake Caliper

Disassembly

CAUTION:

- Before reassembling, check that all parts are free of dust and other foreign particles.
- Replace parts with new ones whenever specified to do so.
- Use only clean brake fluid.
- Make sure no dirt or other foreign matter is allowed to contaminate the brake fluid.
- Do not mix different brands of brake fluid as they may not be compatible.
- Do not spill brake fluid on the car, it may damage the paint; if brake fluid does contact the paint, wash it off immediately with water.

1. Remove the banjo bolt and disconnect the brake hose from the caliper.
2. Remove the caliper bolts, then remove the caliper.

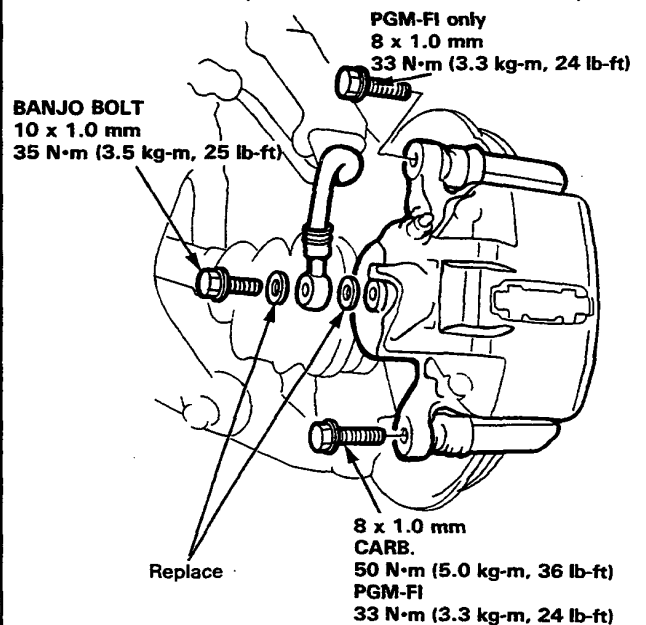

3. Remove the pad spring from the caliper body.

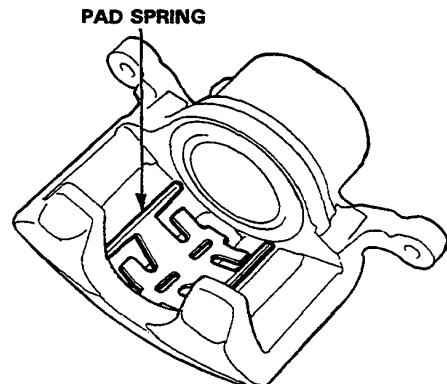

(cont'd)